

17

	V1		P7
1		4	

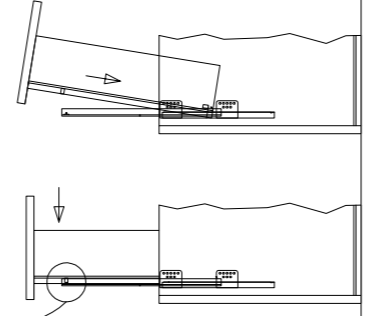

18

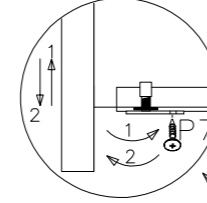
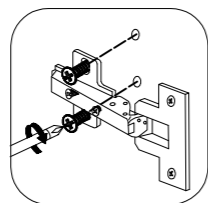
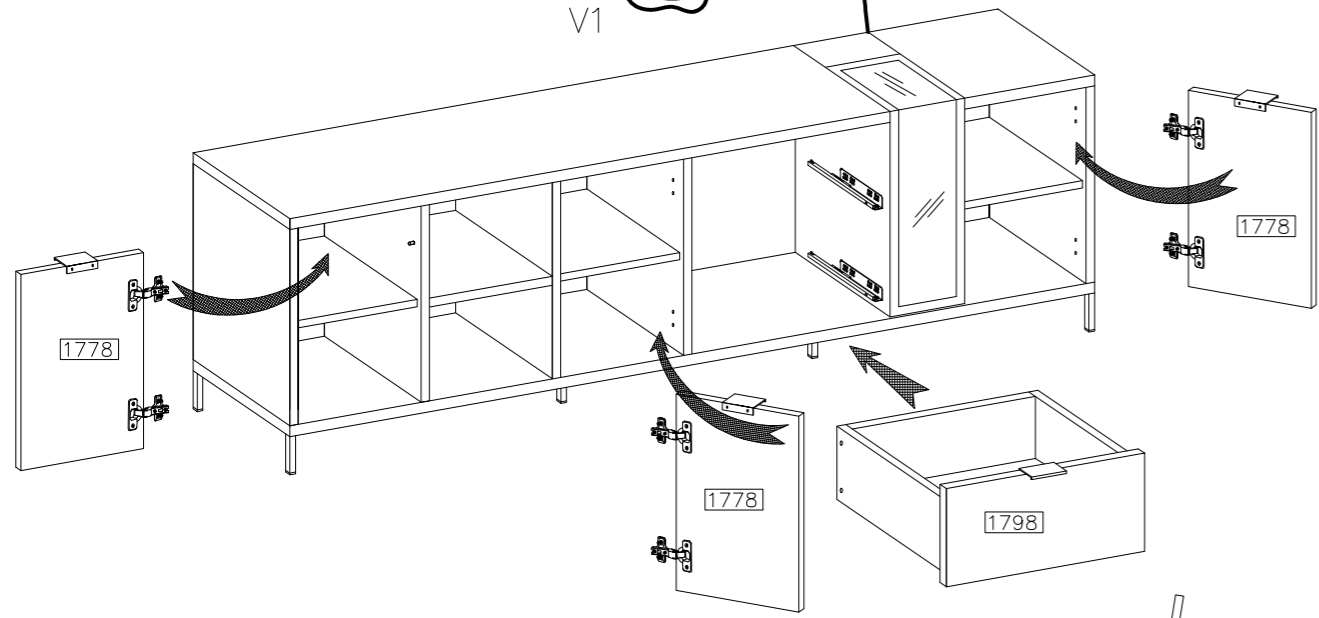
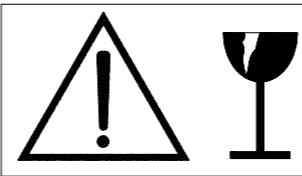
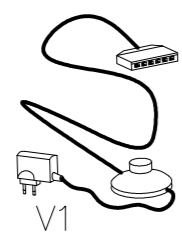
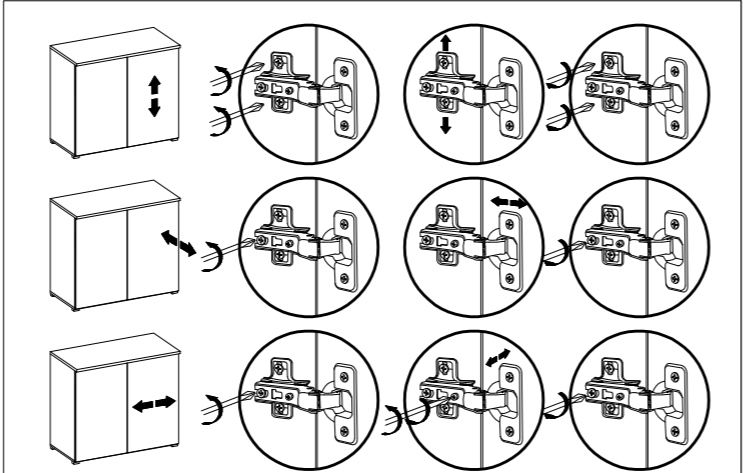
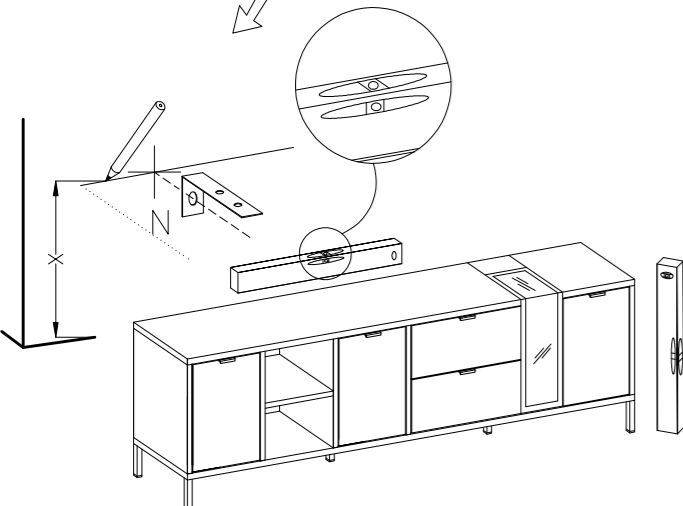
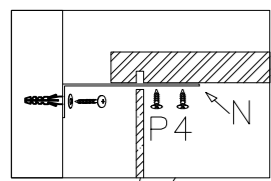
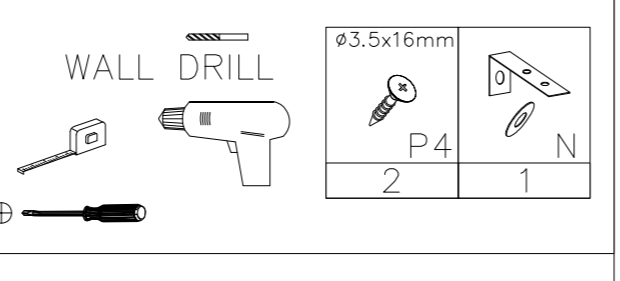
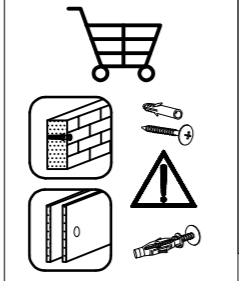
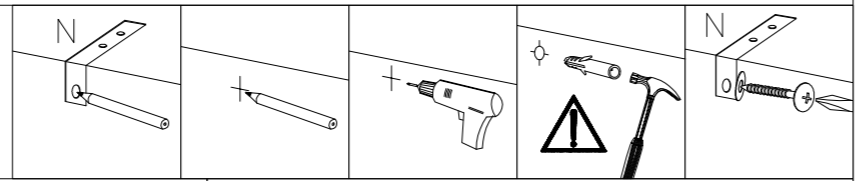

# EVOLUTION EV 04a

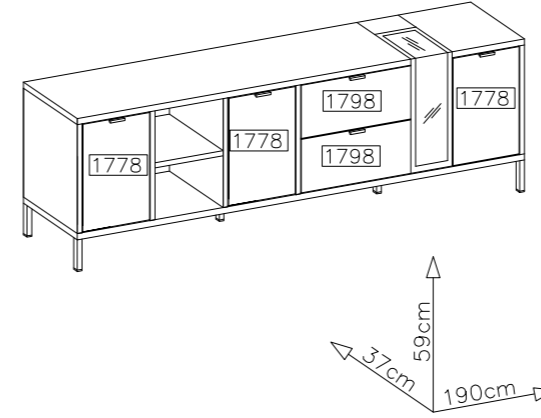
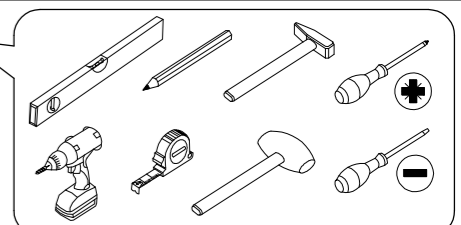
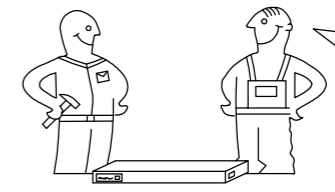

#	ART. NR	L	W	T	Q	Col.No
1	1768	409	370	16	1	1
2	1769	409	370	16	1	1
3	1770	409	350	16	1	1
4	1771	409	350	16	1	1
5	1790	409	350	16	1	1
6	1750	294	320	16	3	2
7	1792	277	340	16	1	2
8	1793	1902	371	16	1	2
9	1752	311	371	16	1	2
10	1795	1390	371	16	1	2
11	1754	201	127	16	1	2
12	1778	290	401	16	3	2
13	1798	455	199	16	2	2
14	1757	300	140	16	2	2
15	1758	300	140	16	2	1
16	1759	420	123	16	2	2
17	1760	435	308	2,5	2	2
18	1803	1397	212	2,5	2	2
19	1785	317	424	2,5	1	2

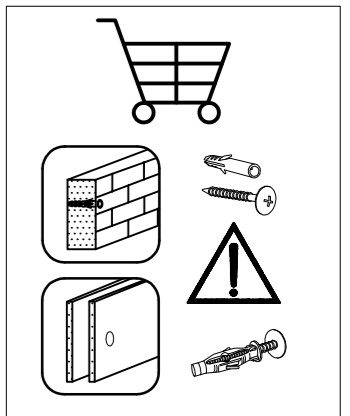
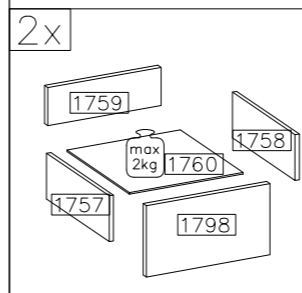
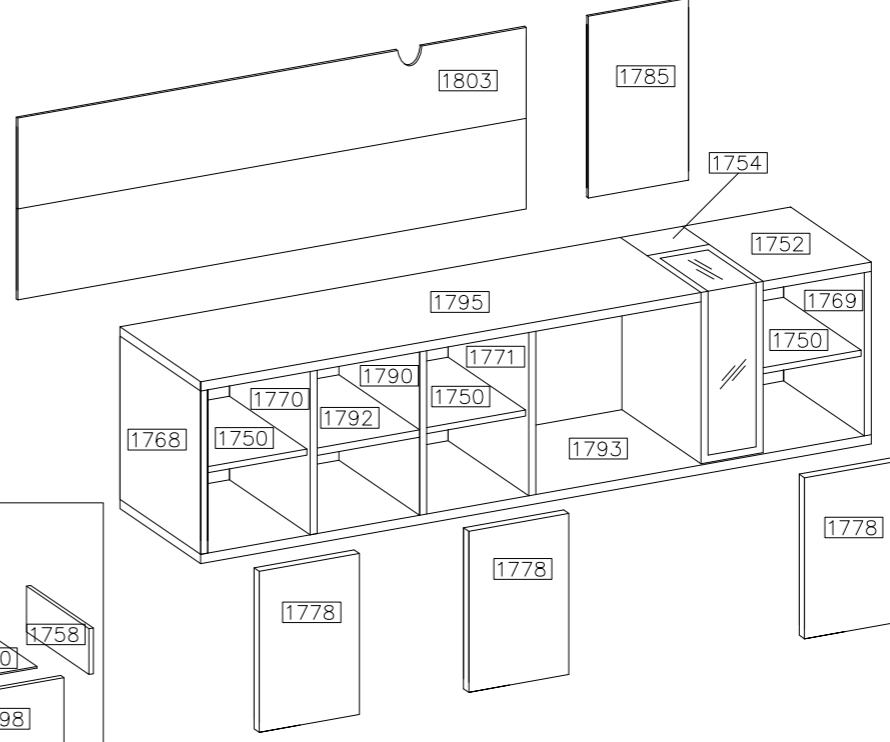
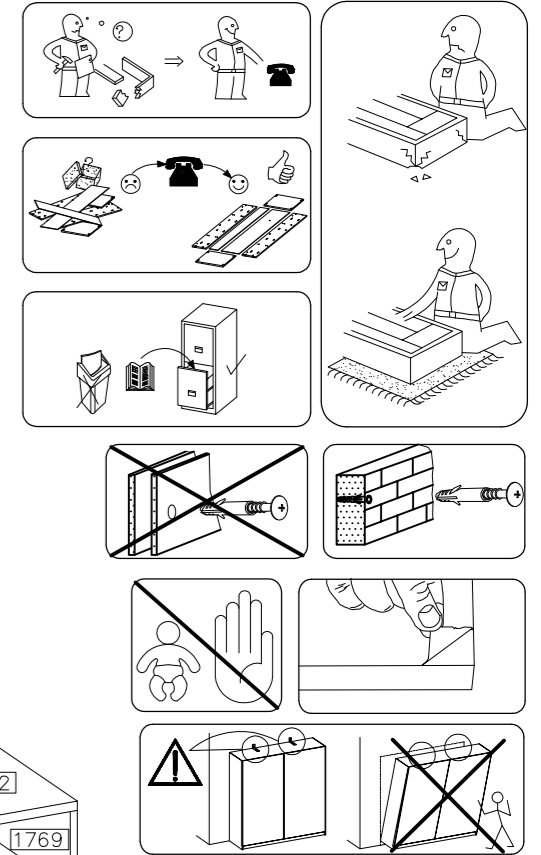

32	4	14	18	14	2	18	14	12	6	14
1	36	5	19	12	1	2SET	25	4		
18	6	4	1	8						



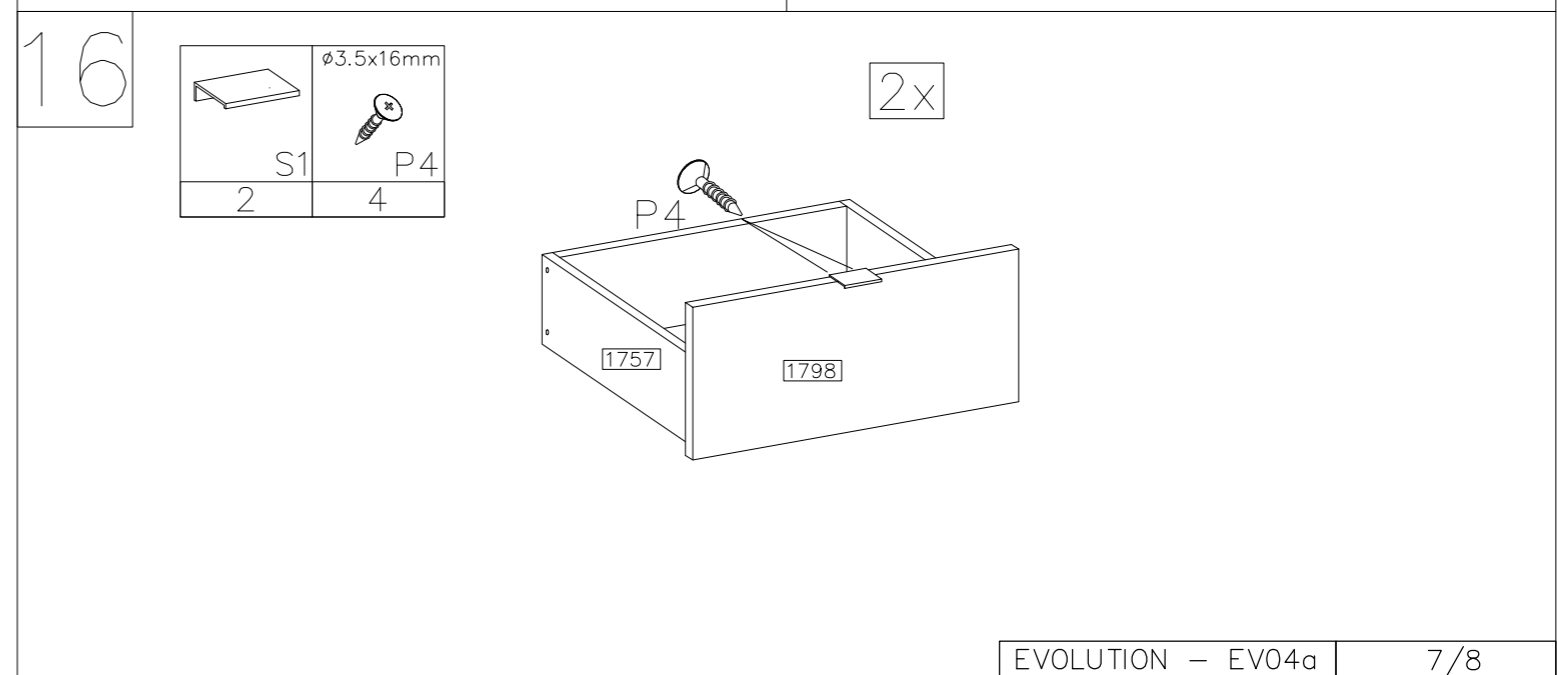
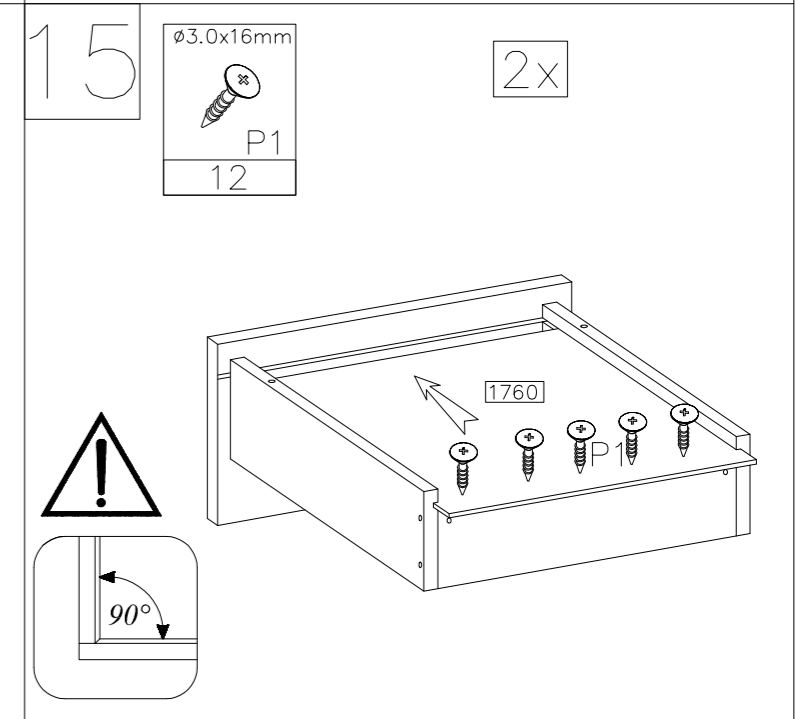
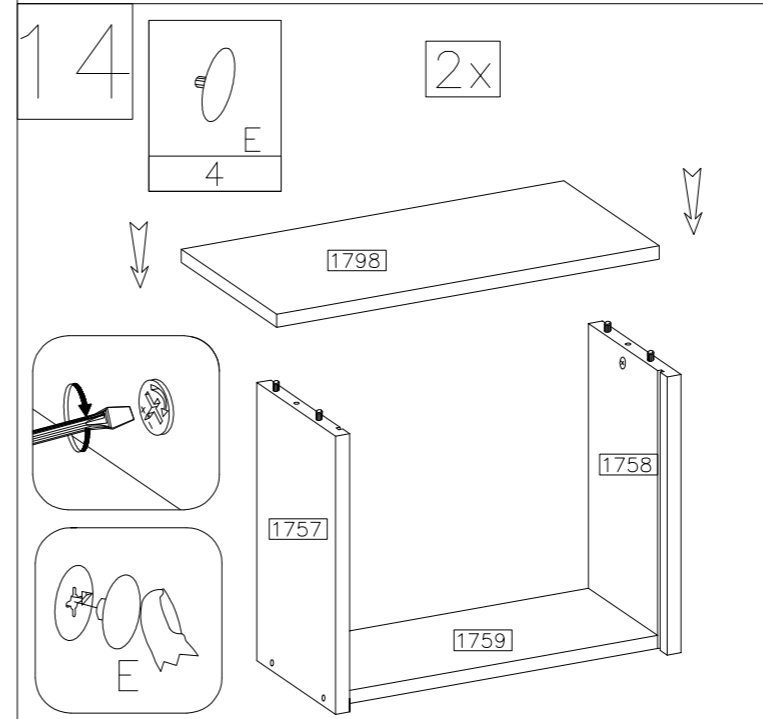
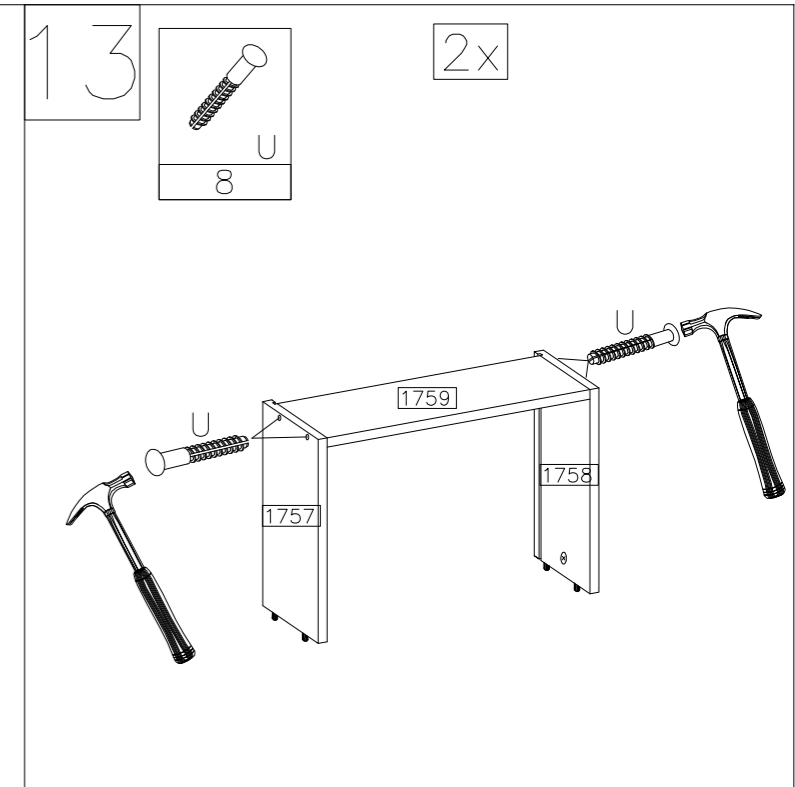
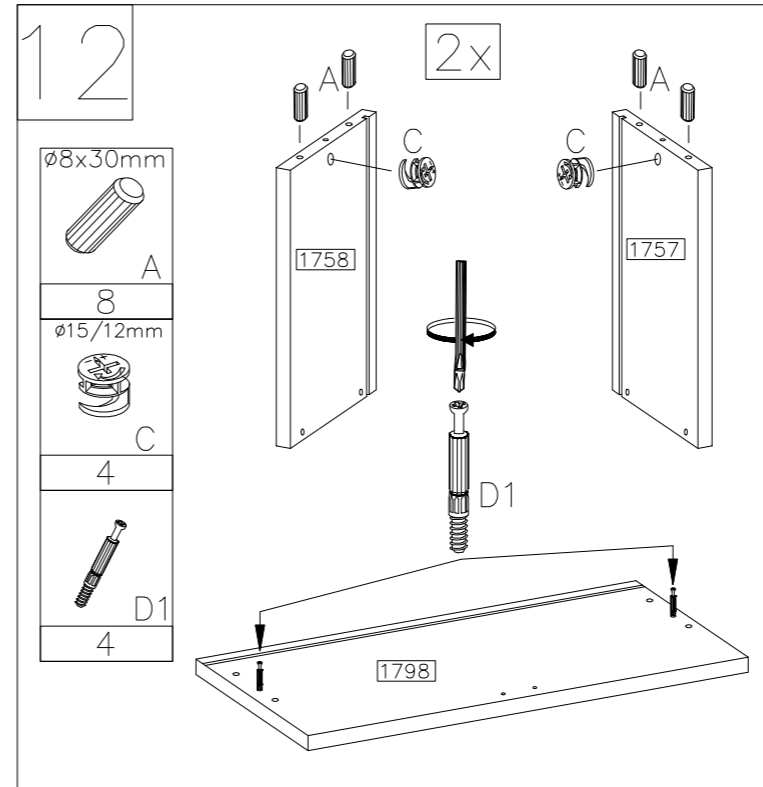
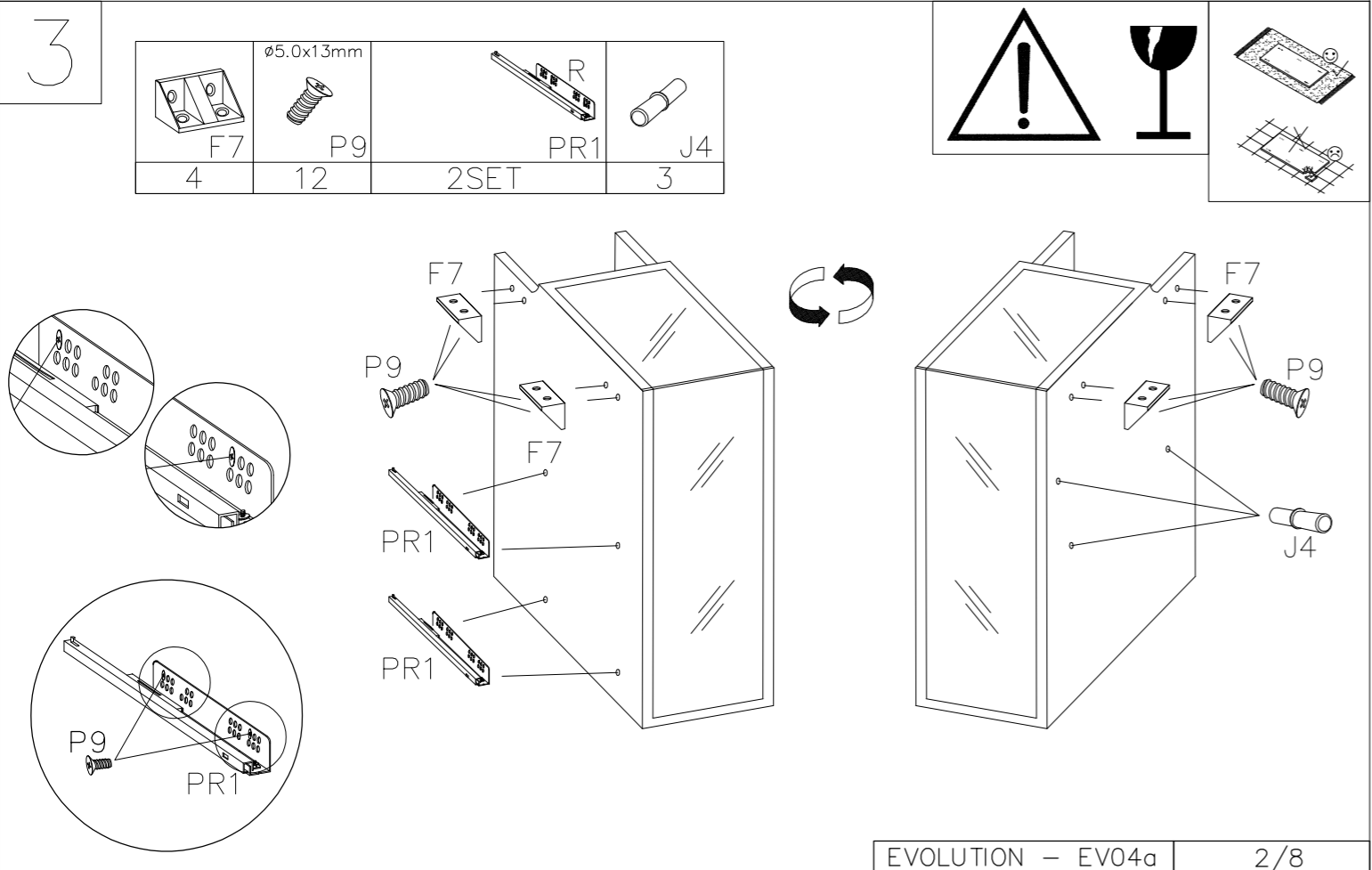
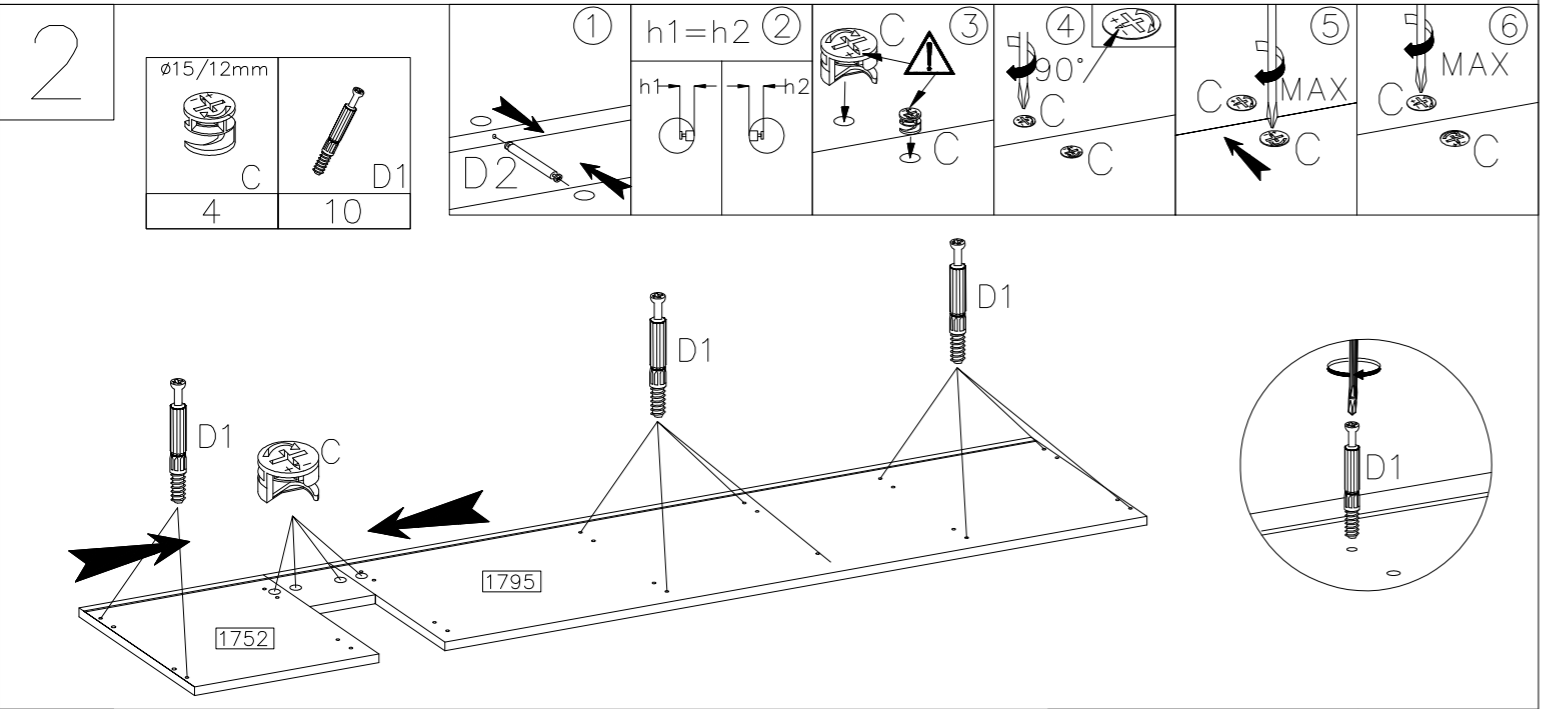
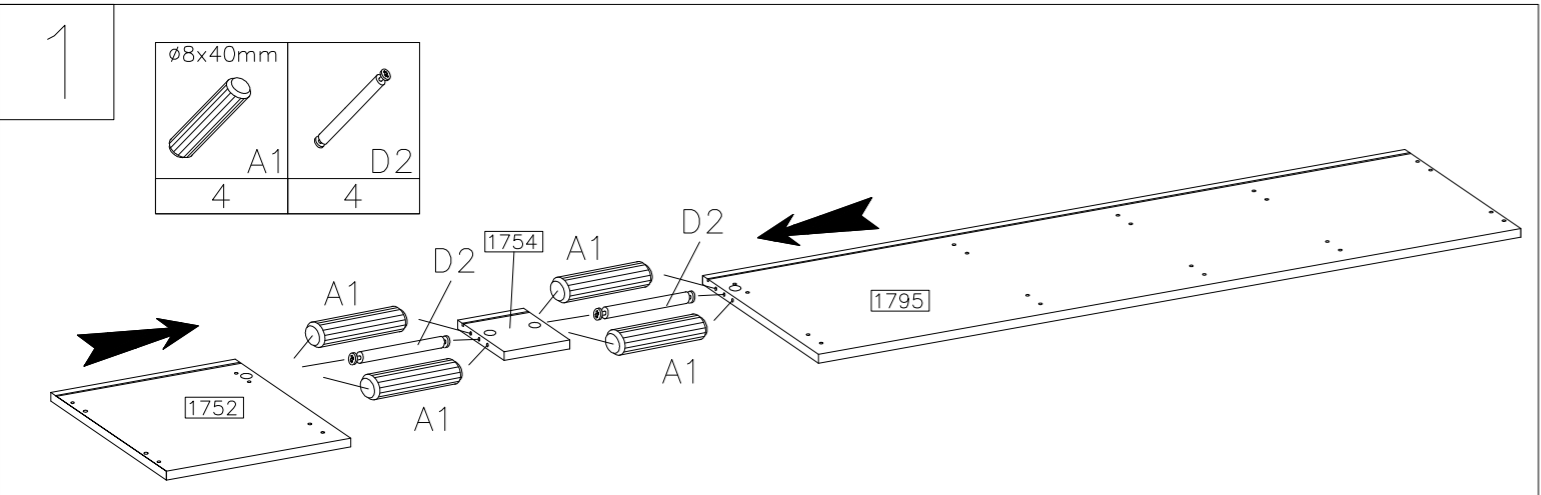

10

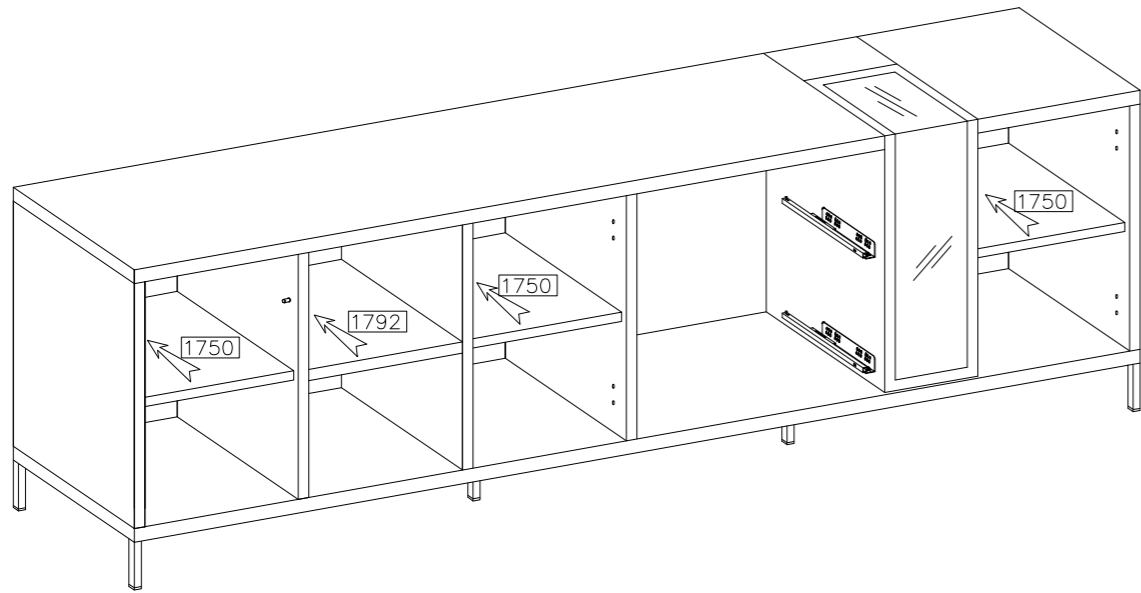

11

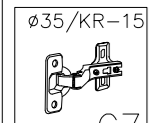

6

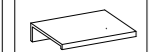

3

5.0x13mm



P9

12

ø3.5x16mm

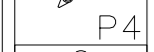

P4

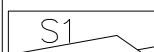

P4

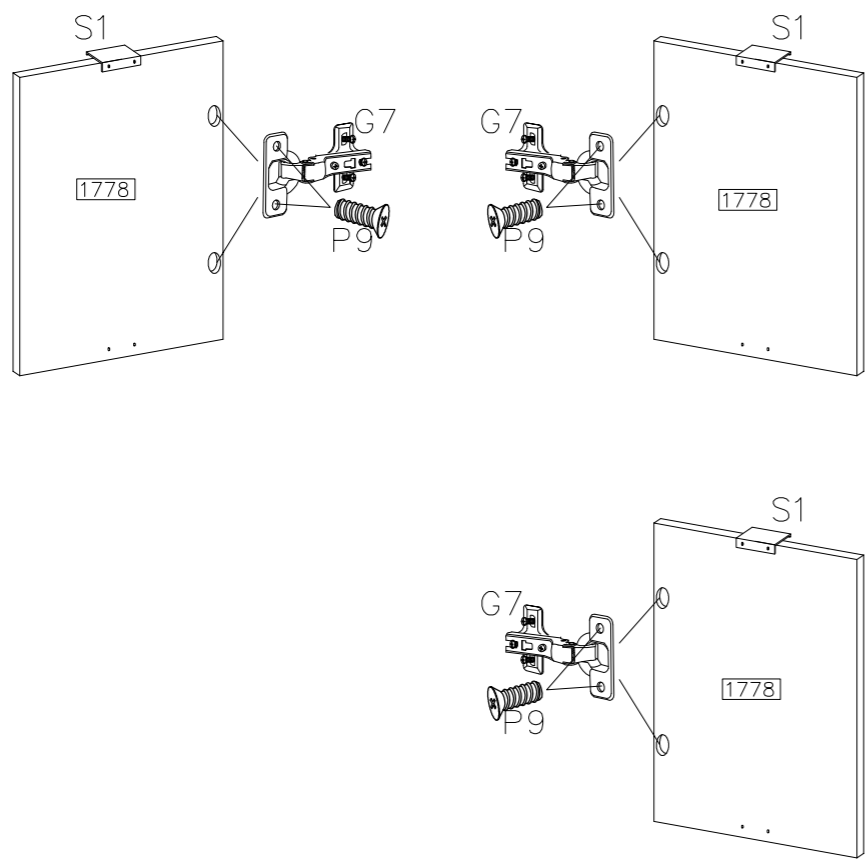

4

ø8x30mm	ø5.0x13mm		
A	J4	P9	PR1
20	16	4	2SET

ø15/12mm	
C	
10	

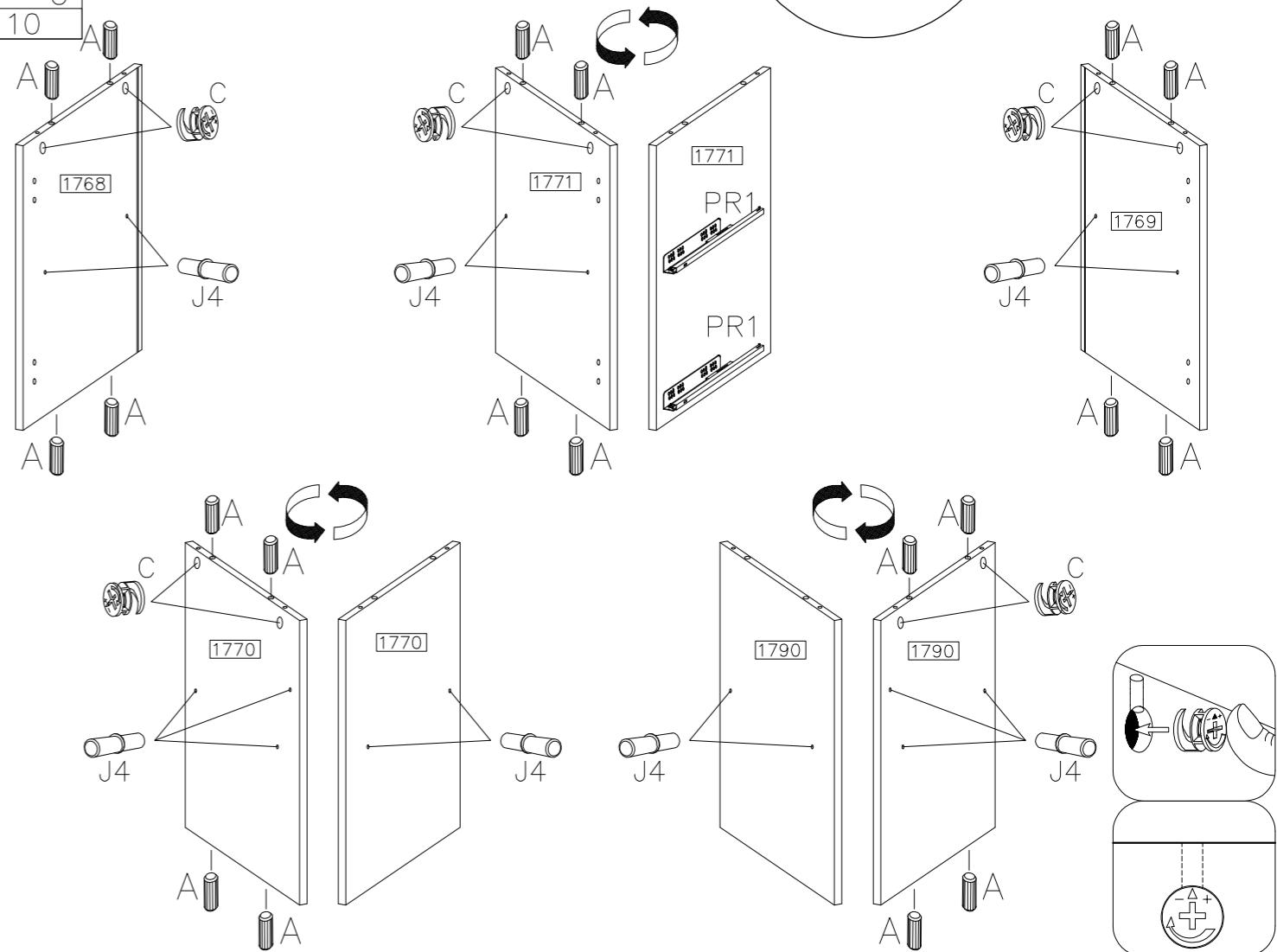

5

ø5.0x13mm		ø8x30mm
P9	E	A
8	10	4

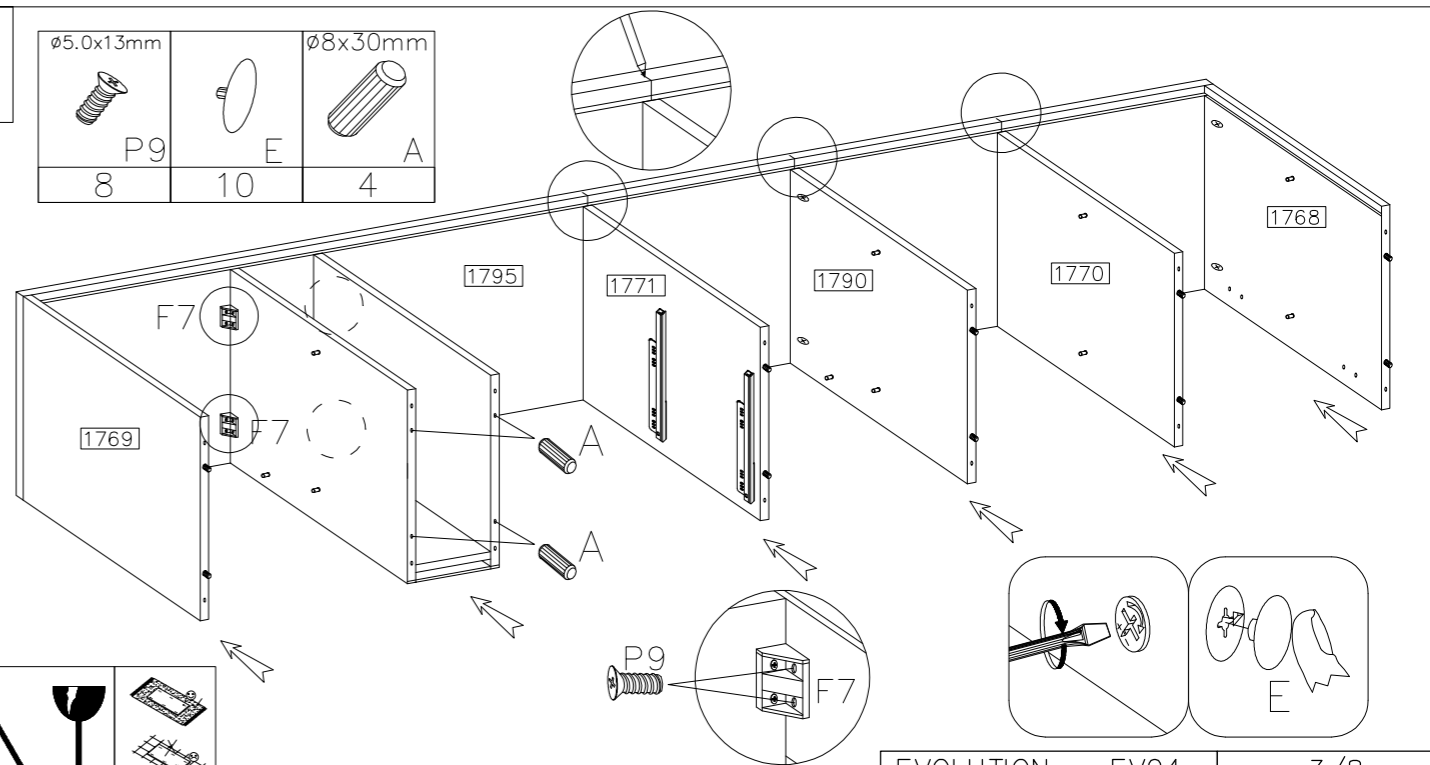

6

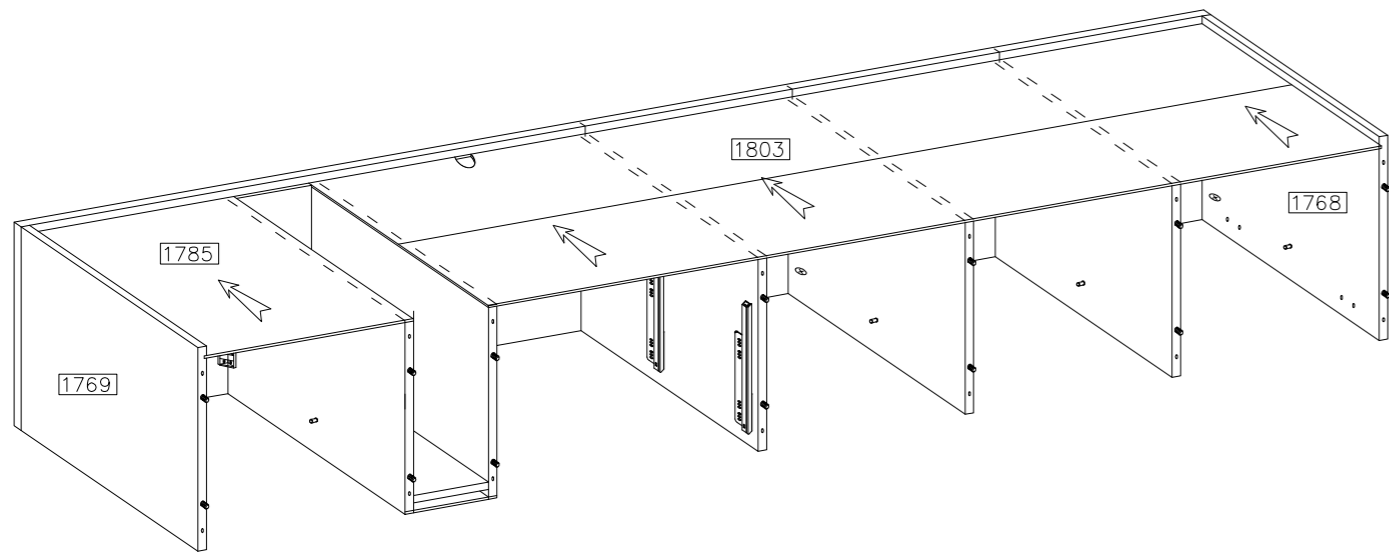
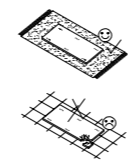
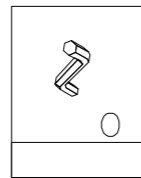

8

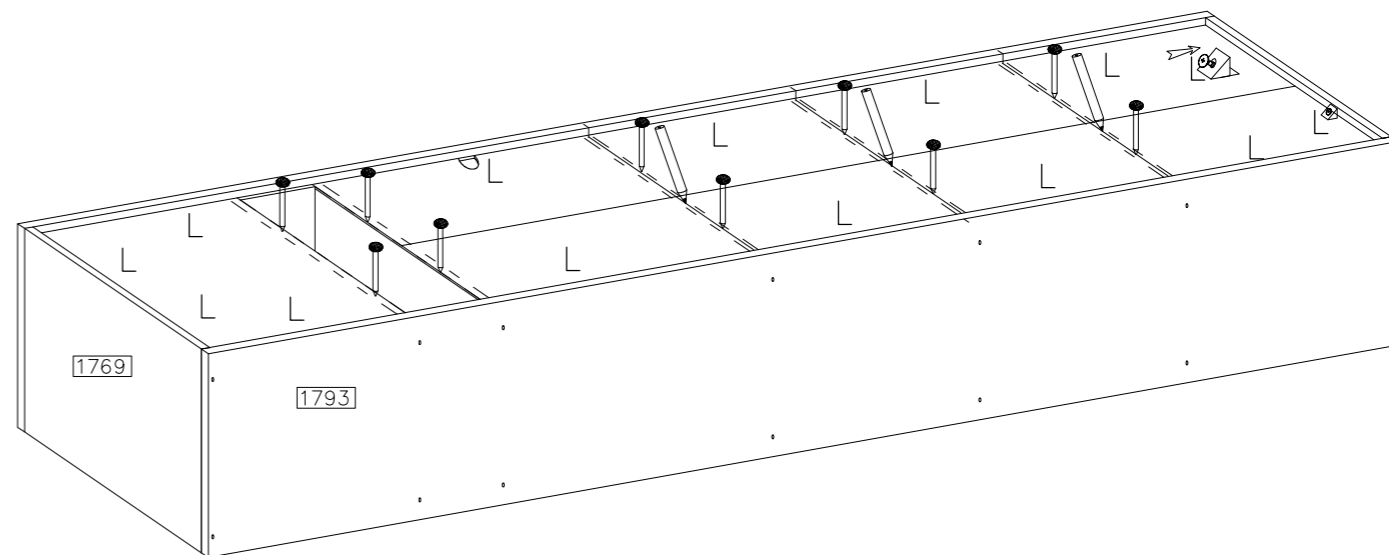
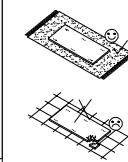
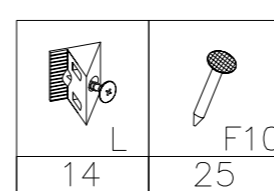

7

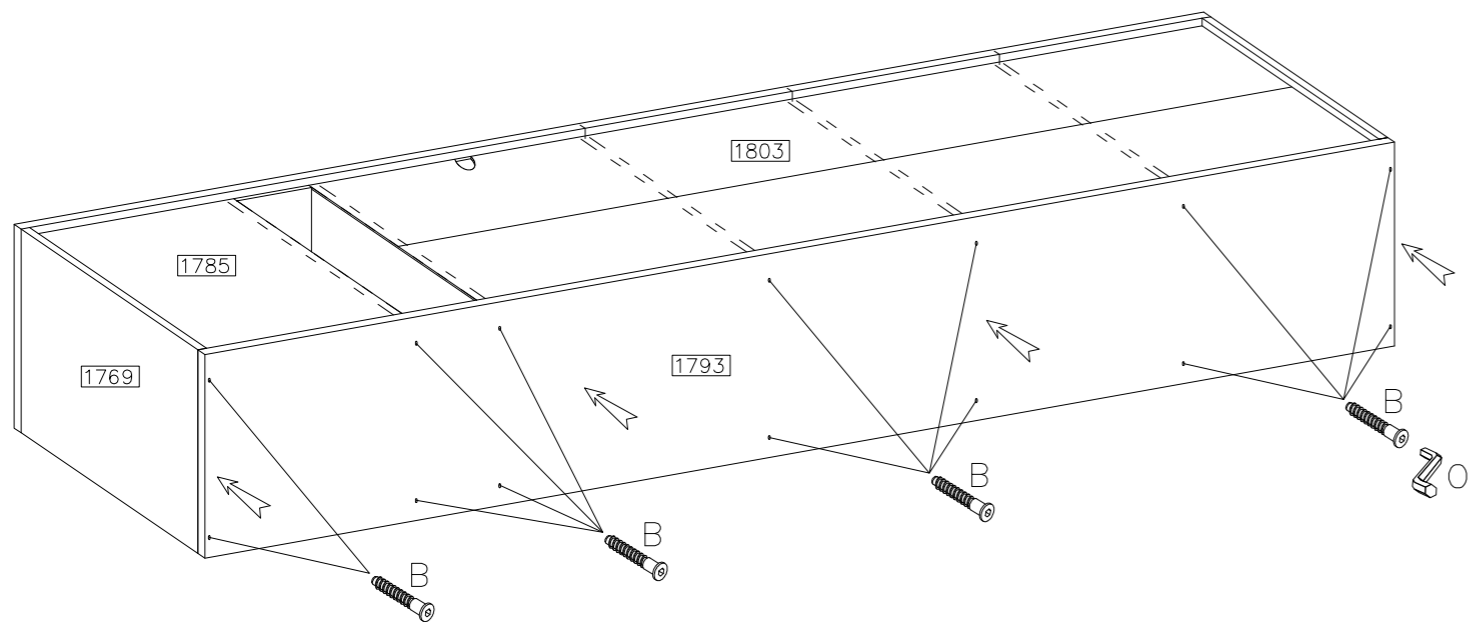
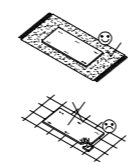
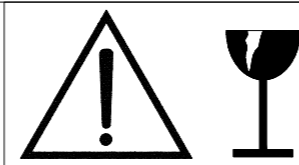
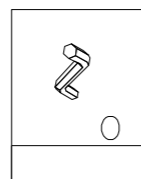
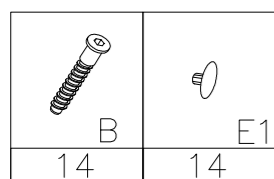

9

